

Keilmembranschieber A19a – Maße

Diaphragm Valve A19a - Dimensions

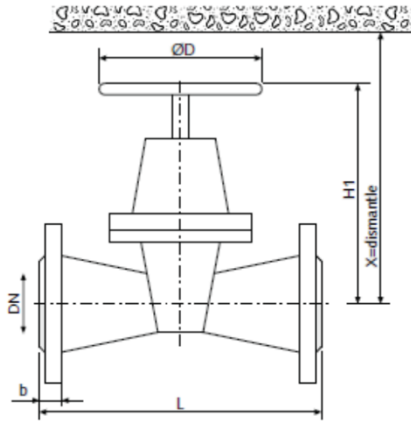

DN 15 – DN 350

p = Betriebsdruck (bar) $p_{\max} \leq 10$ bar /
p = working pressure (bar) $p_{\max} \leq 10$ bar

alle Maße in mm /
all dimensions in mm

DN	15	20	25	40	50	65	80	100	125	150	200	250	300	350
L	130	150	160	200	230	290	310	350	400	480	600	730	850	980
b	15	16	17	18	20	20	22	24	26	26	26	28	30	30
ØD	100	100	100	150	175	225	225	300	300	350	400	500	640	640
H1	85	95	100	160	180	250	260	310	320	360	475	535	670	790
X	140	150	160	220	250	330	350	420	450	520	685	795	980	1150

Hinweis: ab DN 250 p > 8 bar, DN 300 p > 7 bar, DN 350 p > 6 bar Rücksprache erforderlich. DN 32 auf Anfrage
 remark: for DN 250 p > 8 bar, DN 300 p > 7 bar, DN 350 p > 6 bar contact manufacturer. DN 32 on request

Gewicht G (kg) ca. / weight G (kg) appr.

DN	15	20	25	40	50	65	80	100	125	150	200	250	300	350
G	3	4	6	9	13	24	26	34	41	60	120	195	275	380

Technische Änderungen vorbehalten / Toleranz Normmaße nach DIN/ANSI, übrige Maße sind Richtwerte
 Subject to technical changes / Tolerances acc. to DIN/ANSI standards, other dimensions approximate